

FED. ROAD DIST. NO.	STATE	STATE JOB NO.	FISCAL YEAR	SHEET NO.	TOTAL SHEETS
4	OKLA	17020(05)		39	

DESCRIPTION	REVISIONS	DATE
-------------	-----------	------

401 West Dewey, Oklahoma City, Oklahoma 73102  
 Telephone: (405) 521-2000 Fax: (405) 521-8844  
**CONTACTS:**  
 Robert Witt, Director of Engineering Services, Ext. 344  
 James Willey, Chief Engineer, Ext. 348

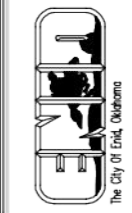

Number	Date	Description
1	10/18/04	This Sheet
2	3/23/05	Specification Reuse Changes

Project Number:	
Project Location:	

Sheet Title:	STANDARD STORM SEWER INLET FRAMES
Project Number:	DD - 3
Project Location:	



Date:	8/1/81
Scale:	NO SCALE
Code File:	OKLAHOMA/SPEC/002-3
Drawn By:	P.B.
Designed By:	R.J.H.
Approved By:	R.J.H.
Sheet:	of

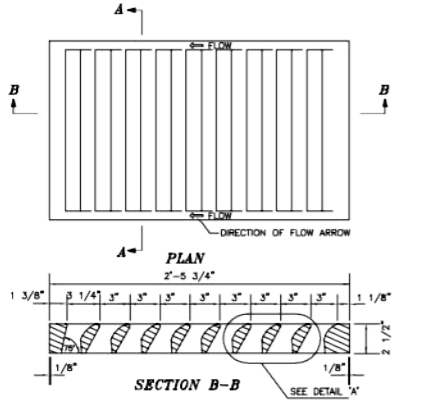

**CAST GRATE**

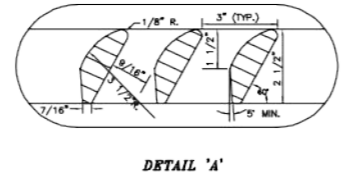

**DETAIL 'A'**

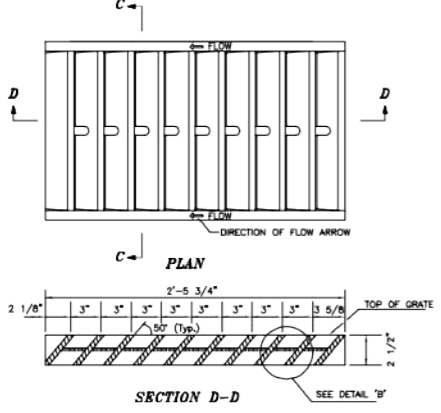

**CAST GRATE**

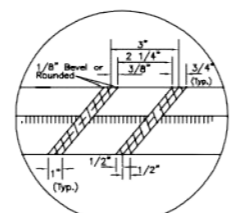

**DETAIL 'B'**

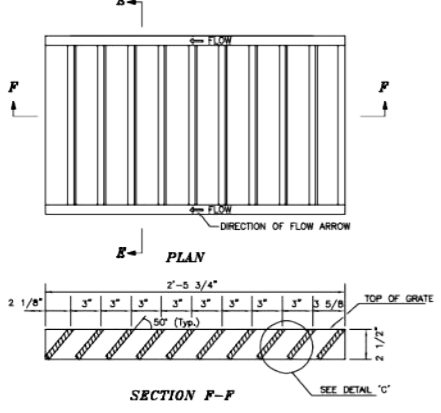

**CAST GRATE**

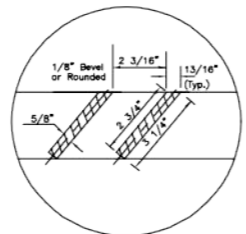

**DETAIL 'C'**

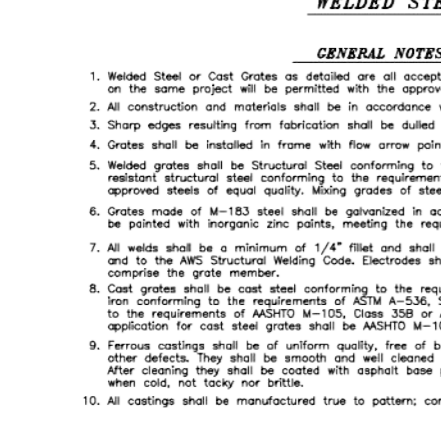

**WELDED STEEL GRATE**

**GENERAL NOTES**

- Welded Steel or Cast Grates as detailed are all acceptable grates. Mixing of alternate types of grates on the same project will be permitted with the approval of the Engineer.
- All construction and materials shall be in accordance with the current Standard Specifications.
- Sharp edges resulting from fabrication shall be dulled by any acceptable method for safety in handling.
- Grates shall be installed in frame with flow arrow pointing downstream or toward the low point in a sump.
- Welded grates shall be Structural Steel conforming to the requirements of AASHTO M-183 or of corrosion resistant structural steel conforming to the requirements of AASHTO M-161 or M-222 or be made of other approved steels of equal quality. Mixing grades of steel on the same grate will not be permitted.
- Grates made of M-183 steel shall be galvanized in accordance with AASHTO M-111 Specifications or shall be painted with inorganic zinc paints, meeting the requirements of the current Standard Specifications.
- All welds shall be a minimum of 1/4" fillet and shall conform to the Specifications for Highway Construction and to the AWS Structural Welding Code. Electrodes shall be compatible to the different grades of steel that comprise the grate member.
- Cast grates shall be cast steel conforming to the requirements of AASHTO M-103, Grade 65-35 of ductile iron conforming to the requirements of ASTM A-536, Special Grade 60-45-10, or of gray iron conforming to the requirements of AASHTO M-105, Class 35B or ASTM A-48, Class 35B. The Specifications of general application for cast steel grates shall be AASHTO M-103, Scope 1.2.1, Grade N-1.
- Ferrous castings shall be of uniform quality, free of blowholes, porosity, hard spots, shrinkage distortion or other defects. They shall be smooth and well cleaned by shot blasting or other approved cleaning method. After cleaning they shall be coated with asphalt base paint resulting in a smooth coating, tough and tenacious when cold, not tacky nor brittle.
- All castings shall be manufactured true to pattern; component parts shall fit together in a satisfactory manner.

The City of Enid  
 401 West Dewey, Oklahoma City, Oklahoma 73102  
 Telephone: (405) 521-2000 Fax: (405) 521-8844  
**CONTACTS:**  
 Robert Witt, Director of Engineering Services, Ext. 344  
 James Willey, Chief Engineer, Ext. 348



Number	Date	Description
1	10/18/04	This Sheet
2	3/23/05	Specification Reuse Changes

Project Number:	
Project Location:	

Sheet Title:	STANDARD STORM SEWER GRATE
Project Number:	DD - 2
Project Location:	



Date:	8/1/81
Scale:	NO SCALE
Code File:	OKLAHOMA/SPEC/002-3
Drawn By:	P.B.
Designed By:	R.J.H.
Approved By:	R.J.H.
Sheet:	of

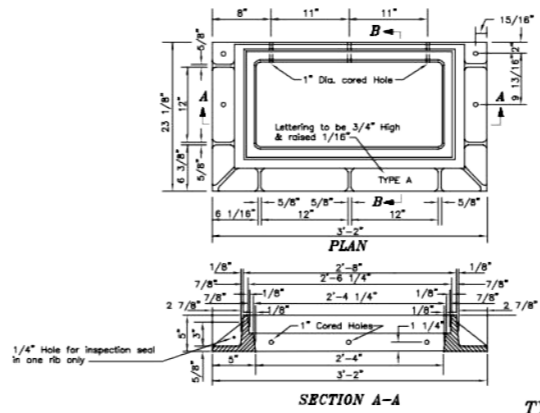

**TYPE "A" FOR INLET DESIGN NO. 1**

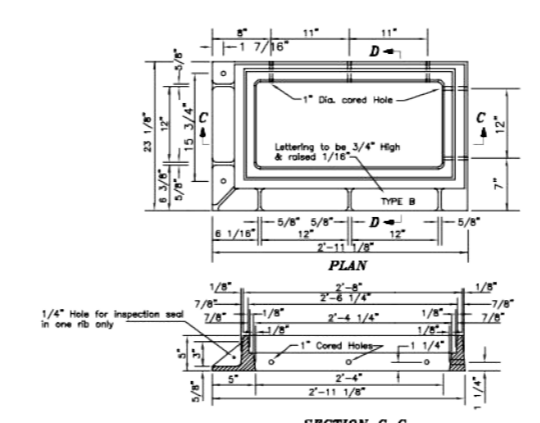

**TYPE "B" FOR INLET DESIGN NO. 2 AND 3.**

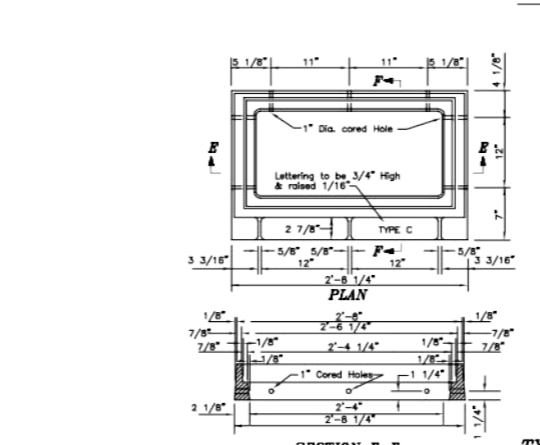

**TYPE "C" FOR INLET DESIGN NO. 3**

- GENERAL NOTES**
- All Construction and Materials requirements shall be in accordance with the current Standard Specifications.
  - Castings shall meet the requirements of AASHTO M-105 Class 20.
  - Inlet Design No. 2 requires 2-Type "B" Frames and 2-3/4" x 5" bolts with nuts to secure Frames together and one I-Beam support (4" x 7.7# x 3'-4"). If built on curved curb the Inlet requires 1-3/4" x 5" bolt and 1-3/4" x 6 1/2" bolt with nut to secure Frames together with 5" x 24" x 3/8" plate spot welded in four places to I-Beam support (4" x 7.7# x 3'-4").
  - Inlet Design No. 3 requires the same appurtenances as Design No. 2 with two or more Type "C" Frames located between the two Type "B" Frames and additional I-Beam support or I-Beam with plate and a pair of bolts with nuts for each Type "C" Frame added plus one additional pair of bolts and support.
  - All bolts required for these structures shall be machine bolts and shall conform to the requirements of AASHTO-164 and shall be Cadmium plated or Galvanized.

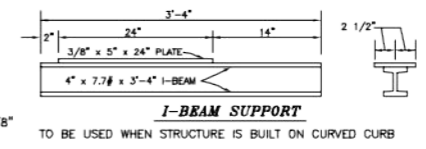

**I-BEAM SUPPORT**  
 TO BE USED WHEN STRUCTURE IS BUILT ON CURVED CURB

DESIGN	Tt
DRAWN	Tt
CHECKED	Tt
APPROVED	DNP
SQUAD	Tt

OKLAHOMA DEPARTMENT OF TRANSPORTATION  
**STANDARD DETAILS**

5/1/2017 10:56:23 AM - P:\2771\21\31\2771-2\300\CAD\SHHEET\DETAILS.DWG - SCHUMACHER, MIKE